

I

T

---

T

T



I I T T

T T T I T T

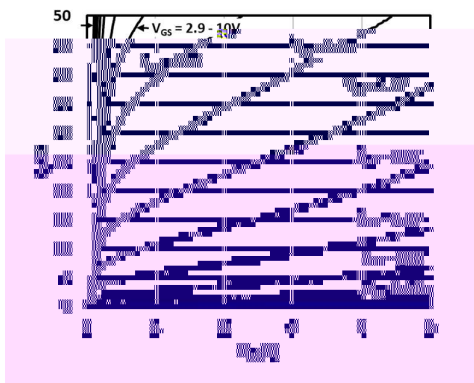

T T T I T T

I T T



T T T I T T

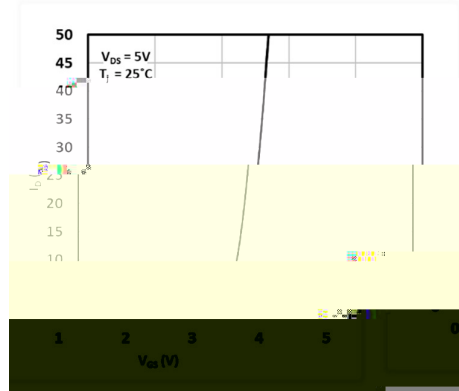

T T T

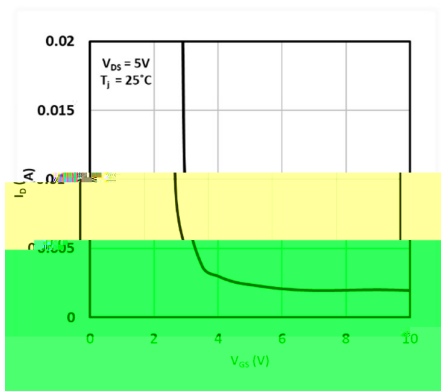

T T T



T

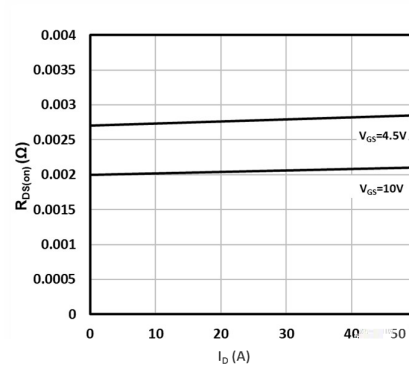

T T

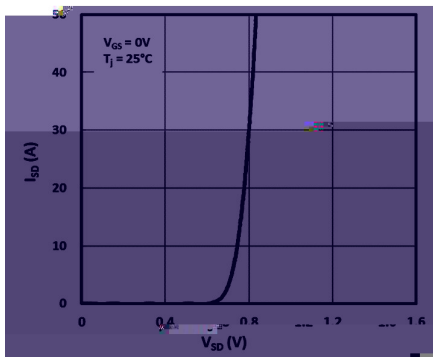

T T T T

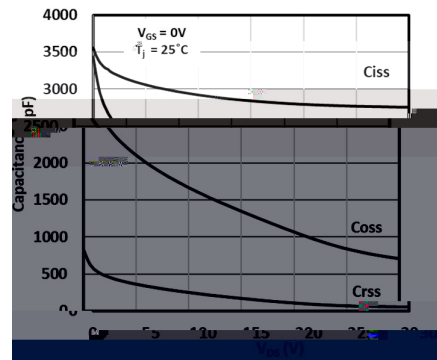

T T T

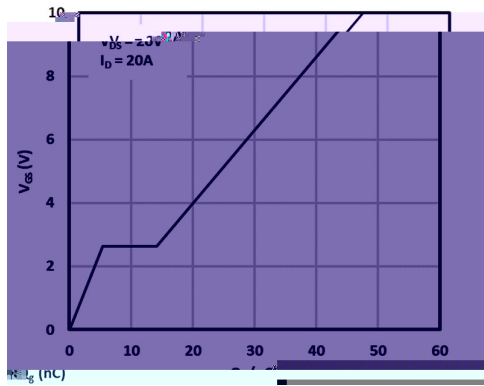

T      T

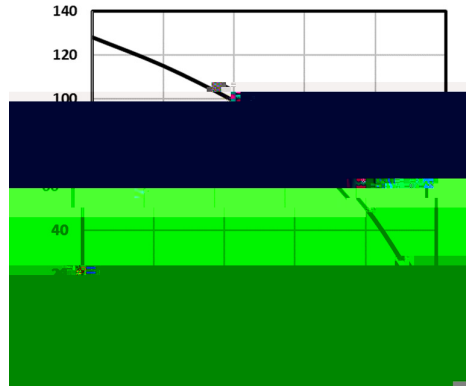

T      T

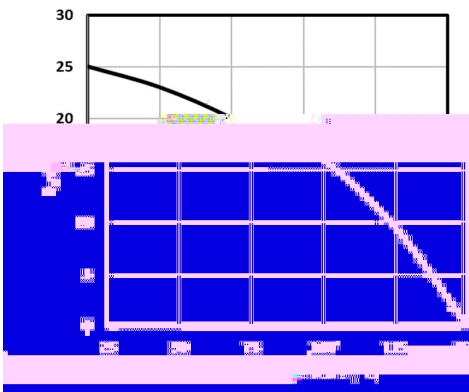

T

T

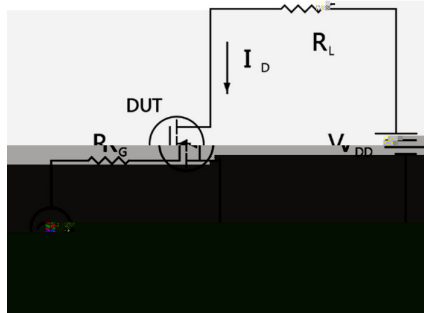

TI

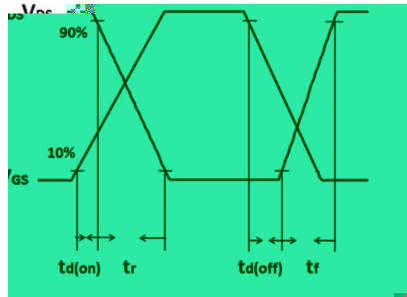

TT

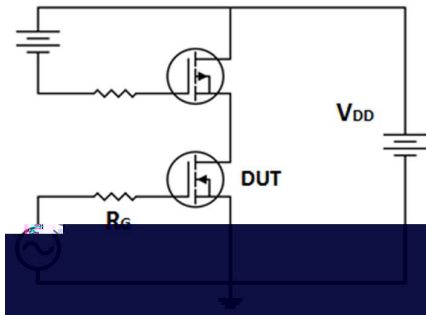

TI



TT

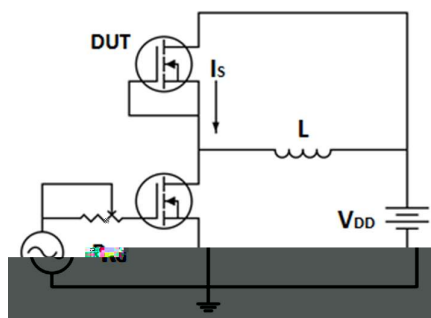

T

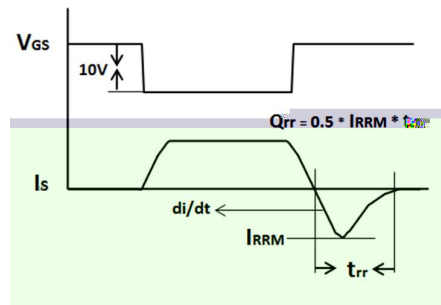

TT

T T T T T

T



I T T

	I	T

T

-

I π -

-

T -

-

T -

T -

T -

T T -